

HDP 120 High Pressure Pump Series

Design criteria

Hammelmann high pressure pumps are built to operate at the continuous maximum duty stated in the performance parameters. Just compare the crankshaft speed, average plunger speed, plunger diameter and power rating.

High pressure pump

Weight: approx. 380 kg

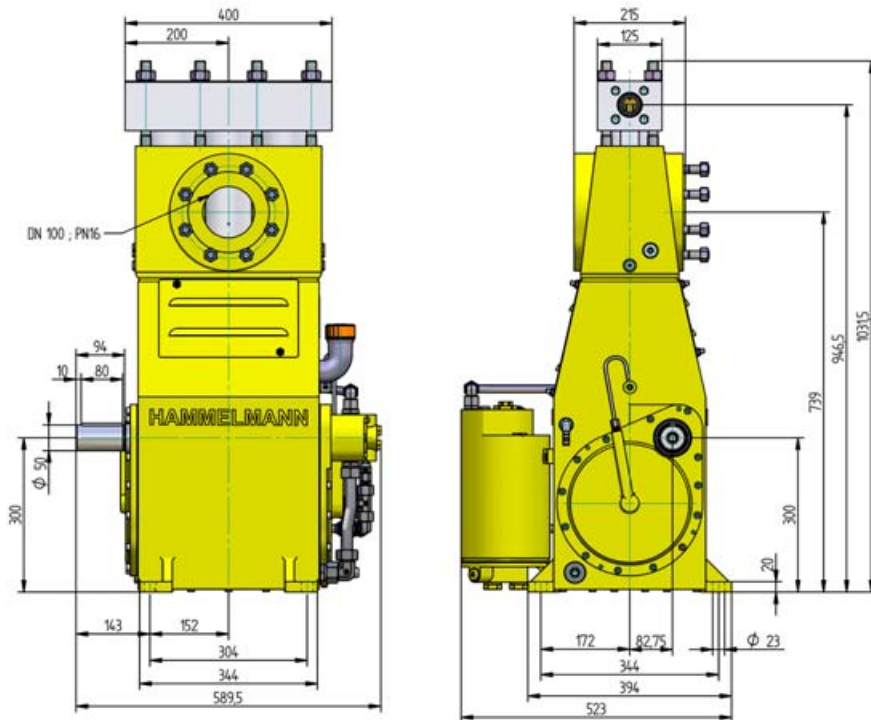

Features

- Power ratings up to 120 kW
- Vertical 3 cylinder design
- Wide variety of complementary ancillaries

Quality and reliability

- Stainless steel stress free pump head
- Bellows form hermetic seal between the suction chamber and crank section
- Choice of application specific seal assemblies
- Solid ceramic or tungsten carbide plungers
- Choice of bronze (standard) or stainless steel suction chamber
- Crank section calculation by 'Finite element method' ensures long working life under continuous load
- Integral speed reduction gear
- Pressurised oil lubrication system with oil cooler/filter

Stationary unit with electric motor

Length: 1856 mm
Width: 850 mm
Height: 1290 mm
Weight: approx. 1600 kg at 110 kW

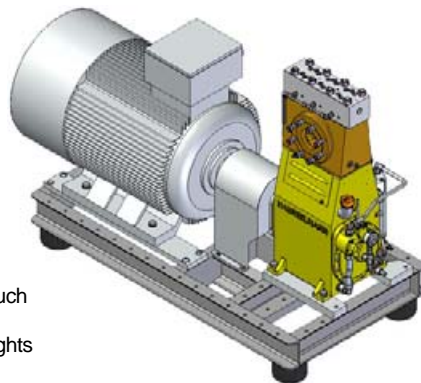

Main dimensions without accessories such as suction line, pressure regulator etc. Detailed dimensional drawings and weights available on request.

Stationary unit with diesel motor

Length: 1990 mm
Width: 1160 mm
Height: 1405 mm
Weight: approx. 1420 kg at 120 kW without full fuel tank

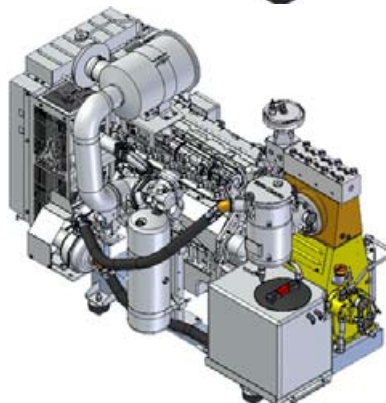

HDP 120 series, technical data

Performance parameters

Q [l/min]*	Required power rating [kW]					D	r.p.m.	
	45	55	75	90	110 /120**		n 1	n 2
	Operating pressure [bar]							
13	1750	2150	2950			17,5	1500	370
16	1450	1750	2450	2900			1500/1800	440
19	1200	1500	2050	2450	3000		1800/2150	530
18	1300	1600	2150	2600		20	1500	370
21	1100	1350	1850	2200	2600		1500/1800	440
25	930	1150	1550	1850	2250/2450		1800/2150	530

* At pressures over 2000 bar approx. 5% of the flow rate is lost due to the compressibility factor of water

28	850	1050	1400	1650		25	1500	370
33	700	850	1200	1400	1650		1500/1800	440
40	600	700	1000	1200	1450/1600		1800/2150	530

40	600	700	1000	1150		30	1500	370
48	500	600	800	1000	1150		1500/1800	440
57	400	500	700	830	1000/1100		1800/2150	530

55	430	530	720	850		35	1500	370
66	360	440	600	720	850		1500/1800	440
78	310	370	510	610	750/820		1800/2150	530

72	330	410	560	650		40	1500	370
87	280	340	460	550	650		1500/1800	440
104	230	280	390	460	570/620		1800/2150	530

92	260	320	440	520		45	1500	370
111	220	270	370	440	520		1500/1800	440
133	180	220	310	370	450/490		1800/2150	530

115	210	260	360	420		50	1500	370
138	180	220	300	360	420		1500/1800	440
165	150	180	250	300	360/400		1800/2150	530

139	180	220	290	350		55	1500	370
166	140	180	250	290	350		1500/1800	440
199	120	150	200	250	300/330		1800/2150	530

167	150	180	250	290		60	1500	370
200	120	150	210	250	290		1500/1800	440
239	100	120	170	200	250/270		1800/2150	530

227	110	130	180	210		70	1500	370
272	90	110	150	180	210		1500/1800	440
326	70	90	120	150	180/200		1800/2150	530

** At n2 = 530 r.p.m.: power rating up to 120 kW

D = Piston/Plunger dia. [mm]
n1 = Motor/Engine r.p.m.
n2 = Crankshaft r.p.m.

Conversion table

Rating	1 kW = 1.34 HP
Op. pressure	1 bar = 14.5 psi
Flow rate	1 l = 0.264 US gallon
	1 l = 0.22 Imp. gallon

Type designations

Sealing system	D	HDP Type
Hydrodynamic with tungsten carbide plungers	17,5 + 20	124
Hydrodynamic with solid ceramic plungers	25	123
Labyrinth with solid ceramic plungers	30 - 70	122
Packed sleeves with solid ceramic plungers	30 - 70	127

D = Piston/Plunger dia. [mm]

- Rod force: 82 kN
- Stroke: 55 mm
- Mean piston speed at n₂
- 370 r.p.m. = 0,67 m/sec
- 440 r.p.m. = 0,81 m/sec
- 530 r.p.m. = 0,96 m/sec

Typical high pressure pump units



- Stationary unit with electric motor



- Road going or stationary trailer units with sound damping cover



- 10 or 20 foot sound damped container versions